



ReVision NET

WEB VIEWING SYSTEM



- ✓ Field of view 350x296 mm
- ✓ Zoom near-losless 16X
- ✓ Web speed up to 1200 m/min
- ✓ Image capture up to 4fps
- ✓ Manual or automatic movement
- ✓ Touch screen Full HD monitor
- ✓ Multi-camera system
- ✓ Quick installation
- ✓ Easy calibration and usability
- ✓ Remote support

ReVision NET is Re S.p.A. new fully integrated web viewing system for the real time check of the printing. A reliable web monitoring system ensures a reduction of the production wastes, increase the printing quality and an important reduction of the setup time.

The ReVision NET system is able to capture the image up to 4 fps to reproduce it in high definition with brilliant and real colours, even at high speeds up to 1200 m/min. The 350 model is provided with a field of view of 350x296 mm to be used for wide format printing and a zoom near-losless 16X to distinguish details up to 40 μm and an automatic system for the attenuation of reflections on plastic or metal materials.

The 24" touch screen FullHD 16:9 monitor together with a user-friendly and intuitive interface, allow the operator to start the job or recall an existing one in just a few seconds, as well as easily navigate through all the numerous functions available. The multi camera option allows the operator to check all the cameras connected to the system from a single control point.

ReVision NET can be provided with manual or automatic movement, single or double monitor and with a wide range of physical and virtual sensors for acquisition synchronization.

ReVision NET is also provided with remote support for system upgrades and check.



TECHNICAL DRAWING

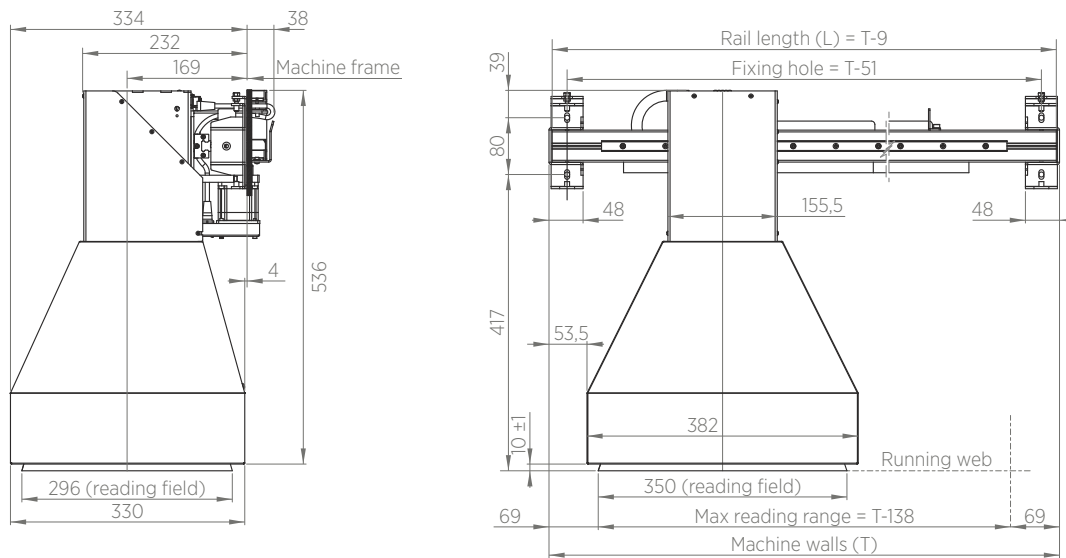

SYSTEM CONFIGURATION

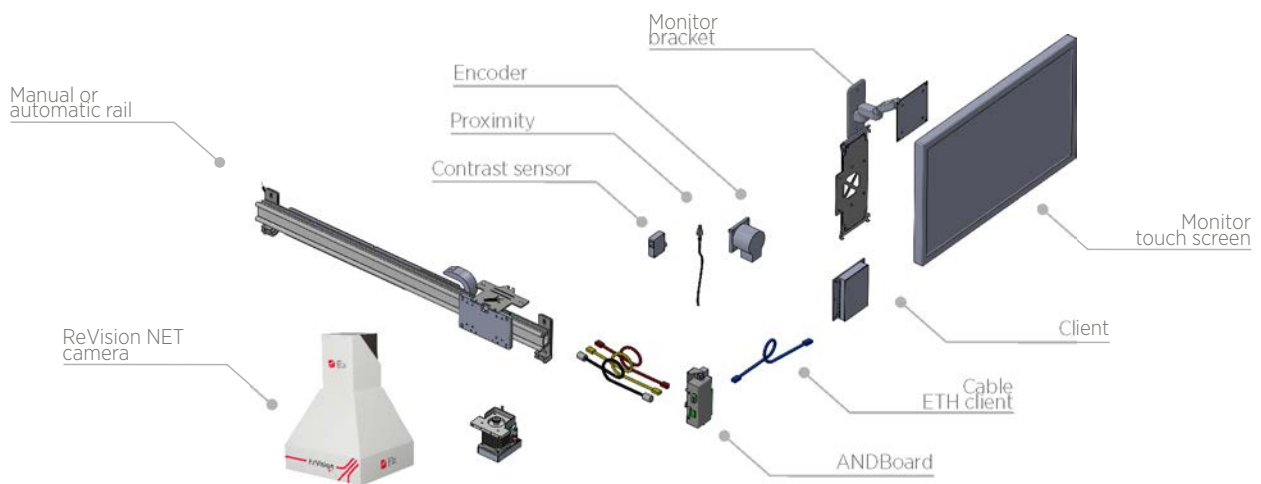

TECHNICAL CHARACTERISTICS

Field of view	350X296 mm
Zoom near-loseless	16x
Max optical magnification (24" FHD)	16x
Image storage	10 works 30 images each
Power supply	24Vdc
Movement	manual or automatic
Max acquiring frequency	up to 4 fps
Max web speed	1200 m/min
Working temperature	0÷50°C
IP protection class	IP20
Remote support	Virtual Private Cloud Re S.p.A.
Monitor	Touch screen 24" FullHD 16.9

*Data are subject to technical change without notice



Re S.p.A.
via Firenze 3
20060 Bussero (MI) Italy

T +39 02 9524301
F +39 02 95038986
E info@re-spa.com

Assistenza tecnica
Technical support
T +39 02 952430.300
E support@re-spa.com

Assistenza commerciale
Sales support
T +39 02 952430.200
E sales@re-spa.com